

PRODUCT SPECIFICATIONS

Model	HR1200-IIA2-S	
Product Type	CLASS II,A2	
Working Voltage&Frequency(V/Hz)	220V 50/60Hz	
Power(W)	210	
Power of Blower(W)	Down DC Fan 120W max Exhaust DC Fan 112W max	
Current(A)	8A (Including Socket)	
Energy consumption (kW.h)	0.21	
Applicable People	1-2	
Airflow Circulation	70%Downflow,30%Exhaust	
Main Filter Typical Efficiency	HEPA,H14,99.995%@0.3µm	
Exhaust Filter Typical Efficiency	HEPA,H14,99.995%@0.3µm	
Filter's Brand	AAF	
Downflow Velocity(m/s)	0.3	
Inflow Velocity(m/s)	0.45	
Fluorescent Lamp Intensity(Lux)	≥1000	
Ultraviolet Lamp	Y	
Clean Level	10# (ISO Class 4)	
Noise(dB(A))	58	
Fan	DC×2	
Fan's Brand	EBM	
Service Valves	4(2 on each side)	
Outlets	2(1 on each side)	
Net/Gross Weight	kg	320/360
	lbs	705.5/793.0
Internal Dimensions(W*D*H)	mm	1310*620*630
	in	51.5*24.4*24.8
External Dimensions(W*D*H)	mm	1380*780*1465
	in	54.3*30.7*57.7
Packing Dimensions(W*D*H)	mm	1470*920*1690
	in	57.9*36.2*66.5
Working Height of Front Window(mm)	200	
Stand	680-900mm adjustable height	
Container Load (20'/40'/40'H)	8/16/16	
Alarm	Sound and Flash	
Certificate	CE, BS EN 12469, TUV	

Note:If a slight difference occurs between pictures and actual products, please refer to actual products. Our company reserves the right of final interpretation of this brochure, please contact us for any further information if required.

Haier Biomedical

Intelligent Protection of Life Science

Class II Biosafety Cabinets



Energy Efficient
Dual DC fans and LED lights to reduce energy consumption.

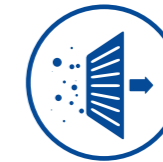

High Efficiency Filter
High efficiency HEPA filter for downflow air - typical efficiency of 99.995% for 0.3µm particle



Side Glass Windows
Glass wall allows more natural light in, reducing optical stress caused by artificial lighting, as well as maximising the usable space.

Haier Biomedical's single exhaust filtered Class II microbiological safety cabinet offers three levels of protection: operator, product and environment.

Safer by Design

The HR1200-IIA2-S biological safety cabinet utilises one highly efficient HEPA exhaust filter and one HEPA downflow filter to provide three levels of protection: operator, product and environment. As there is no need for external ducting, this is a cost-effective solution.

The unit is certified to the EN 12469 standard. It uses energy efficient DC fans, as well as LED lights to ensure for optimal performance with a low noise output and reduced energy consumption. The ergonomic design ensures maximum comfort and alleviates operator fatigue.



Patented Technologies

The range incorporates two patented technologies which offer total user protection and improves the cabinet's energy efficiency.



Patented Safe Airflow Disruption System

The units utilise side air design on the upper edge and on both sides of the front window to eliminate 'blind spots'. This prevents crossflow between inside and outside air, reducing contamination.



Certified to EN 12469 Standard

HEPA exhaust filters – typical efficiency of >99.995% for 0.3 micron particles. HEPA filter (downflow) provides vertical laminar flow to the worktable.



Multiple Alarm Functions

Clear and easy to understand alarm with visual and sound alert functions. Alarms include filter and UV end-of-life alerts, fan turned-off after door opening alert and door open alarm.



Easy to Clean

The divided work surface can easily be removed for sterilisation and allows for easy access to the base of the cabinet for cleaning. The unique drop-down front glass window can be removed in seconds to enable quick and efficient cleaning of upper sections, limiting downtime. There is also a stainless steel rear wall and easy to access drain valve.



Ergonomic Design

Designed with the user in mind, this cabinet features 10° angled front window to provide a comfortable workspace, adjustable height stand, castors with self-levelling feet and a drop-down window design for easy cleaning. A removable hand rest reduces arm fatigue without interfering with the air inflow.



Lower Noise and Airflow Uniformity

DC fan operates with lower noise and better uniformity airflow.



Patented Waterproof Socket Timer

The two IP rated 44 waterproof sockets within the cabinet have a timed on/off function for improved safety and energy conservation.



Simple Controller with LCD screen display

LCD control panel displays various parameters and clear operational conditions.



Two Service Fixtures

Two access ports are located on either side of the cabinet for easy access and flexibility.



UV Lamp

Ultraviolet light can be set with one single key to automate on/off time, sterilisation time and sterilisation time interval from 0 to 24 hours, reducing downtime.



Tubular Motor (Optional)

The motor is stable and reliable. Two position limiting devices make the auto glass-door system more safe.



Optional Electric Glass Door

The glass door is electrically operated. The standard glass-height opening during work is set to 200mm. The glass door can also be pulled down – in order to allow easy access for complete and effective cleaning and decontamination.

PRODUCT ADVANTAGES



EBM DC Fan, Energy consumption as low as 112W, Low noise to 58 dB.



Standard waterproof socket. (Option water valve and air valve.)



AAF HEPA filter, The filtration efficiency is 99.995% @ 0.3 um.



Electrical glass door motor make the use procedure more comfortable. (Optional)



Adjustable chassis adapts to different height requirements.



Drop-down glass door is easy to clean



Compartmented working surface is easy to be sterilised and cleaned.

PRODUCT DIMENSION DRAWING

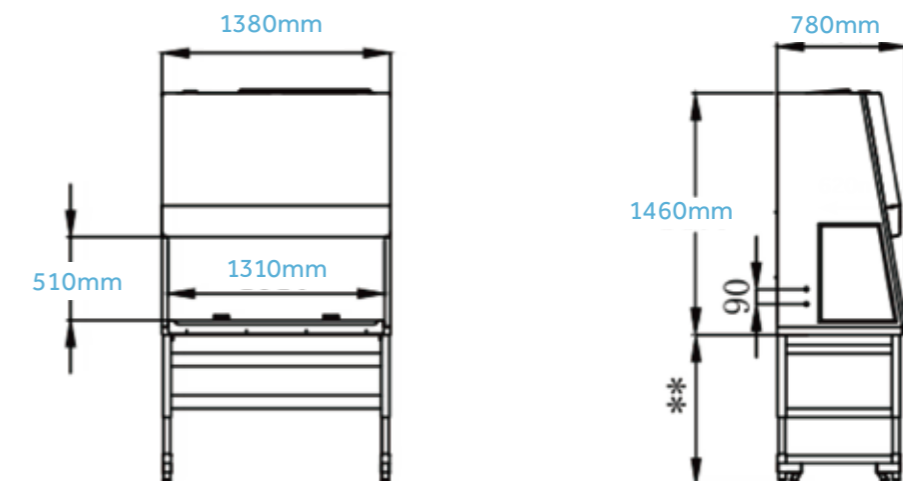

** Height adjustable stand, adjustable range: 680-900mm



WolfLabs

Pricing on any accessories shown can be found by keying the part number into the search box on our website.

The specifications listed in this brochure are subject to change by the manufacturer and therefore cannot be guaranteed to be correct. If there are aspects of the specification that must be guaranteed, please provide these to our sales team so that details can be confirmed.

www.wolflabs.co.uk

Tel : 01759 301142

Fax : 01759 301143

sales@wolflabs.co.uk

Please contact us if this literature doesn't answer all your questions.